

Gardner
Denver

RECIPROCATING AIR COMPRESSORS

Locomotive Compressors



Locomotive Compressor Evolution

Proven Performance

Gardner Denver has been building air compressors and compressor-exhausters for diesel-electric locomotives since 1935. Locomotive compressors perform the critical function of operating the air or vacuum braking systems and other accessories in the locomotive. Our complete line of locomotive air compressors and compressor-exhausters includes 3 cylinder, 4 cylinder, and 6 cylinder models.

The first Gardner Denver compressors designed for locomotive use were water-cooled. Air-cooled compressors came into use in the 1940's for diesel electric freight locomotives that incorporated a car body design that directed a free flow of air to the air compressor. In the 1950's, enclosed car body freight locomotives were built with higher horsepower engines that required the use of water-cooled compressors. Gardner Denver currently offers both water-cooled and air-cooled compressors and compressor-exhausters for a variety of locomotive applications. We have the engineering capability to design a compressor to meet your specific locomotive requirements.



Serviceability in Mind

Downtime is costly and the locomotive compressors were designed with ease-of-service in mind. The design and location of the valves is critical since valve maintenance and replacement is one of the items that is most often serviced on the compressor. The Gardner Denver compressor design incorporates valves that are reliable, highly efficient, easy to access, and quick to replace. To reduce service intervals, the crankcase has been designed with a larger oil capacity for longer oil life, as well as reduced maintenance through lower oil temperatures. The compressors are built with a full flow, spin-on oil filter for improved life and reliability. The compressor design includes a gear-driven positive displacement oil pump that provides pressurized lubrication under all operating conditions including low idle speeds.

These compressors have been designed to perform in harsh environments such as tropical heat, desert sandstorms, monsoons and arctic cold.

Gardner Denver locomotive compressors have been designed with reliability, serviceability, and efficiency in mind.

We are committed to product research and development to assure that the current locomotive compressors include the latest advancements in technology, design and materials. Gardner Denver locomotive compressors have provided proven performance that is measured in decades.

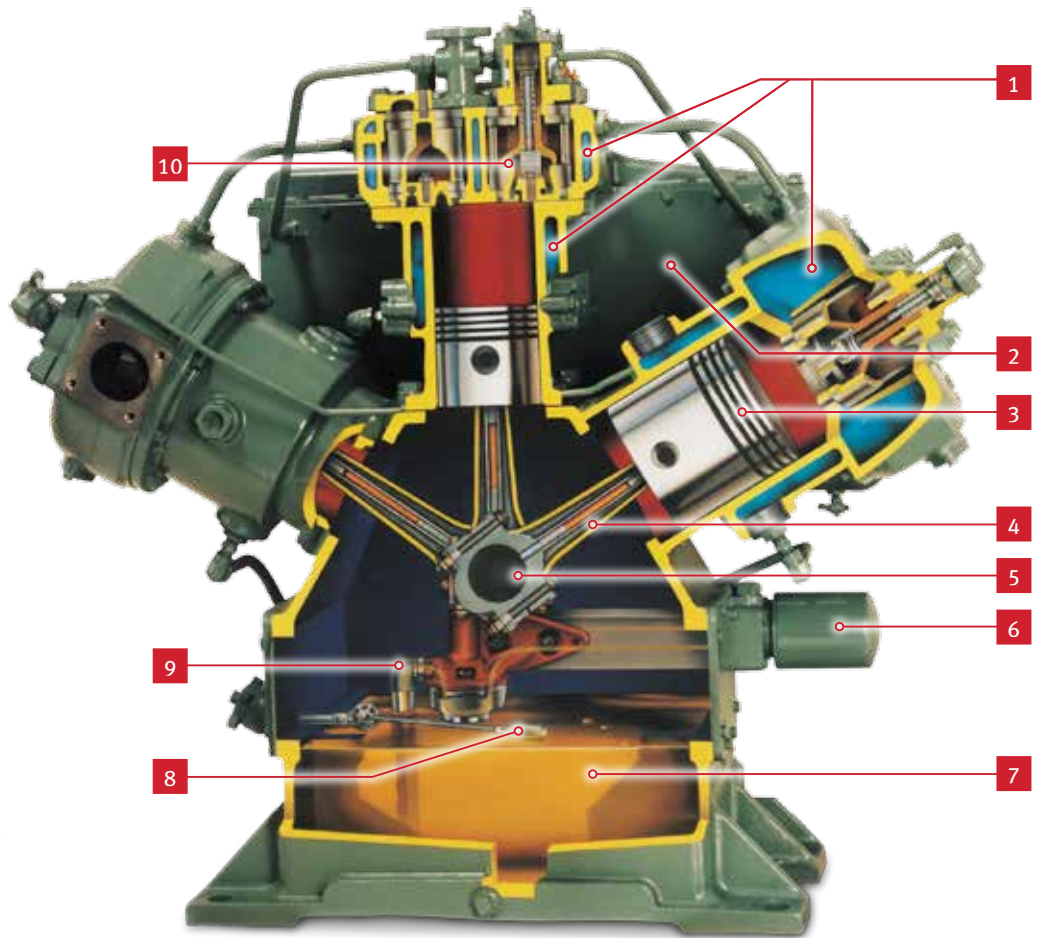

Locomotive Compressor Features

- 1** Choice of air or water cooled compressors. Water cooled models have cylinders and valve pockets fully jacketed for maximum heat dissipation.
- 2** All two-stage models come equipped with an intercooler.
- 3** Pistons, rings and cylinders are designed for optimum oil control. Cylinders are manufactured to gauge quality roundness, with tolerances measured in millionths of an inch. Exclusive Gardner Denver piston and piston ring design significantly reduces oil carry over into the air stream.
- 4** Rifle drilled connecting rods provide pressurized lubrication to the wrist pin for low speed operation.
- 5** Ductile iron crankshaft, single or double ended, is precision designed and supported by large tapered roller bearings, with drive gear for the oil pump. Bearings have a B-10 life of 75,000 hours.
- 6** Full flow, spin on oil filter for improved life and reliability.
- 7** Large oil capacity crankcase prolongs oil life and reduces maintenance costs by lowering oil temperatures.
- 8** Float with oil level gauge for positive oil level indication.
- 9** Positive displacement oil pump, gear driven by the compressor crankshaft, provides pressurized lubrication under all operating conditions, including low idle speed.
- 10** Low lift valves for improved volumetric efficiency and reliability at high engine speeds.

COMPRESSOR DATA

COMPRESSOR FEATURES	GD MODEL					
	WLV	WLU	WLA	WLN	WLT	WLG
Number of Cylinders	2	3	4	3	3	6
Bore	7 $\frac{7}{8}$ x 4 $\frac{1}{4}$	7 $\frac{7}{8}$ x 5 $\frac{3}{4}$	7 $\frac{7}{8}$ x 4 $\frac{1}{4}$	7 $\frac{7}{8}$ x 5 $\frac{3}{4}$	7 $\frac{7}{8}$ x 5 $\frac{3}{4}$	7 x 5 $\frac{3}{4}$
Stroke	4 $\frac{1}{2}$	4	5	5	4	5
No. LP & HP Cylinders	1 LP & 1 HP	2 LP & 1 HP	2 LP & 2 HP	2 LP & 1 HP	2 LP & 1 HP	4 LP & 2 HP
Cooling	Water Cooled	Water Cooled	Water Cooled	Water Cooled	Air Cooled	Water Cooled
Speeds 500-1050	Yes	Yes	Yes	Yes	Yes	Yes
ICFM @ 1050 RPM	97	170	220	213	170	400
Max BHP @ 1050 RPM	30	48	64	65	48	125
CCW Rotation from Drive Shaft	Yes	Yes	Yes	Yes	Yes	Yes
Intercooler with Drain	Yes	Yes	Yes	Yes	Yes	Yes
95% Continuous Operation Cycle	Yes	Yes	Yes	Yes	Yes	Yes
Approx. Compressor Weight—Lbs	840	1820	2260	1635	1390	2410

COMPRESSOR/EXHAUSTER DATA

COMPRESSOR FEATURES	GD MODEL			
	WLP	WLQ	WLR	WLS
Number of Cylinders	4	6	6	6
Compressor Bore Size	7 $\frac{7}{8}$ x 4	7 $\frac{7}{8}$ x 4	7 $\frac{7}{8}$ x 5 $\frac{3}{4}$	7 $\frac{7}{8}$ x 4
Stroke	5	5	5	5
No. LP & HP Cylinders	1 LP & 1 HP	1 LP & 1 HP	2 LP & 1 HP	1 LP & 1 HP
Vacuum Bore Size	8 $\frac{1}{2}$	7 $\frac{7}{8}$	7 $\frac{7}{8}$	8 $\frac{1}{2}$
No. Vacuum Cylinders	2	4	3	4
Cooling	Air/Water Cooled	Air Cooled	Air Cooled	Air Cooled
Speeds 500-1050	Yes	Yes	Max 950 RPM	Yes
ICFM @ 1050 RPM & 140 PSIG	117 CFM	117 CFM	177 CFM	117 CFM
Max BHP @ 1050 RPM & 140 PSIG	41 BHP	46 BHP	64 BHP	51 BHP
CCW Rotation from Drive Shaft	Yes	Yes	Yes	Yes
Intercooler with Drain	Yes	Yes	Yes	Yes
95% Continuous Operation Cycle	Yes	Yes	Yes	Yes
Approx. Compressor Weight—Lbs	1340 LBS	1978 LBS	2240 LBS	1810 LBS



Gardner Denver, Inc.

1800 Gardner Expressway
Quincy, IL 62305
866-440-6241

www.gardnerdenverproducts.com

